

POKER SORT™

REMOVES LONG, TROUBLESOME POKERS
FROM SHREDDED MATERIAL



Eriez' new **PokerSort™** extracts long, troublesome pokers like automotive leaf springs, tie rods, steering and axle components and other generally uncooperative long shapes directly from the shred before the drum magnet. As pokers exit the shredder, alignment guides on the incline conveyor position poker-type objects parallel in the flow. As pokers reach the end of the conveyor, they extend beyond the conveyor and are magnetically pulled over the **PokerSort**, into a chute and collect in a bin or bunker.

The belt-driven **PokerSorts** are 18-inches in diameter and available in a range of sizes from 36 to 96-inches wide. In most cases, **PokerSort** can be retrofitted to meet existing ferrous processing set-ups.

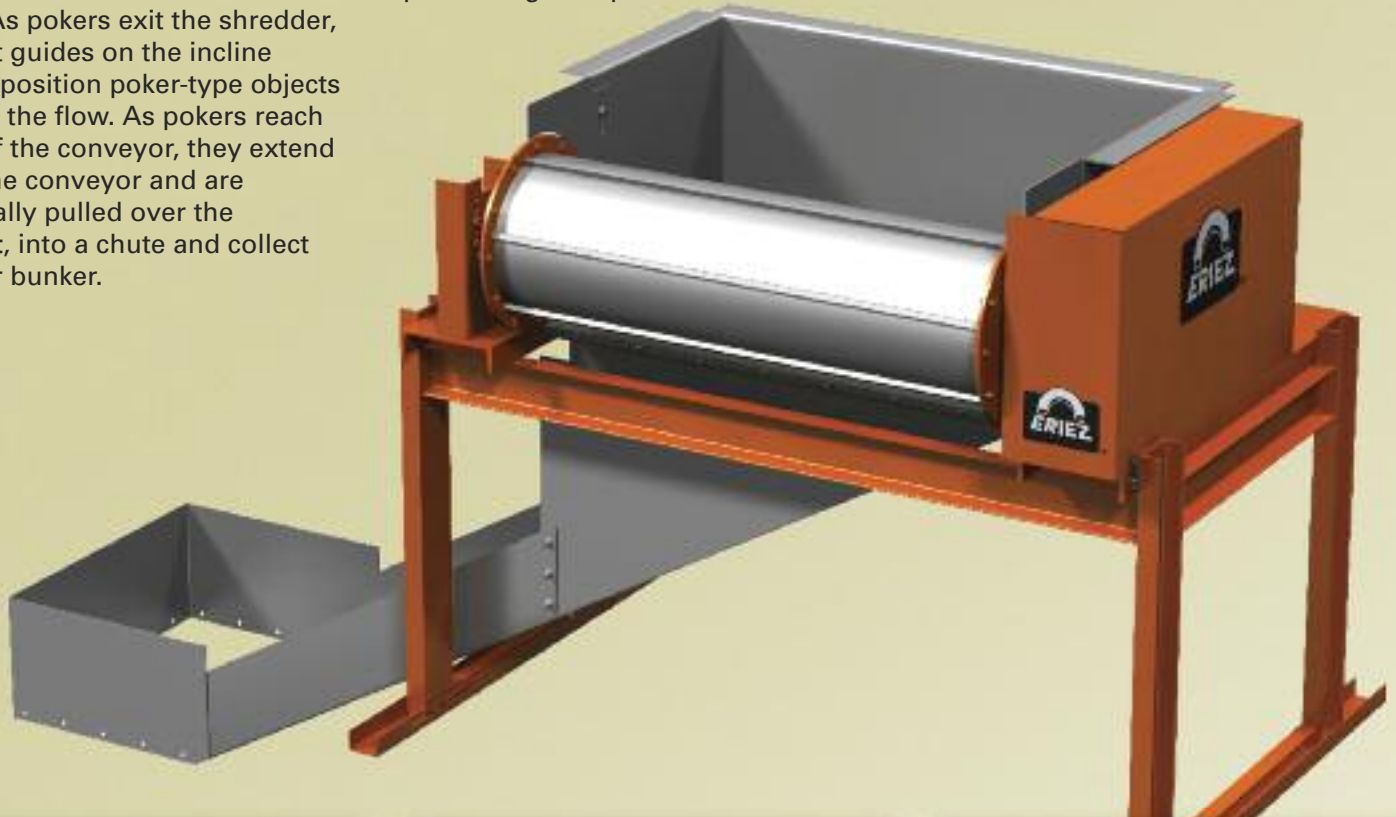

Note: Some safety warning labels or guarding may have been removed before photographing this equipment.

Eriez and Eriez Magnetics are registered trademarks of Eriez Manufacturing Co, Erie, PA

©2012 ERIEZ MAGNETICS

ALL RIGHTS RESERVED



World Authority in Advanced Technology for Magnetic, Vibratory and Inspection Applications

Headquarters: 2200 Asbury Road, Erie, PA 16506-1402 U.S.A.

Telephone: 814/835-6000 • 800/345-4946 • Fax: 814/838-4960 • International Fax: 814/833-3348

Web Site: <http://www.eriez.com> e-mail: eriez@eriez.com

Manufacturing Facilities: AUSTRALIA • BRAZIL • CANADA • CHINA • INDIA • JAPAN • MEXICO • SOUTH AFRICA • UNITED KINGDOM • UNITED STATES